

EFFICIENT SOLUTIONS FOR EVERY TYPE OF INSTALLATION

**DOOR DETECTORS  
LIGHTING SOLUTIONS  
SECURITY SYSTEMS  
SPECIALISED PRODUCTS**

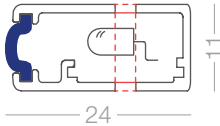



**COMPACT**  
MODEL 03.G5.A174

- 174 beams from 36 diodes
- Standard height of 2000mm
- IP54 rating
- Immune to sunlight
- Detecting range of 4000mm

OTHER MODELS:

- 03.G5.A94.R24  
17 beams / 94 diodes / Direct connection

**81-20**  
COMPLIANT

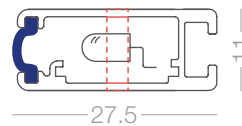

**VERSATILE**  
MODELS 03.G5.L 174/194

- 174/194 beams from 36/40 diodes
- Standard height of 2000mm
- IP54 rating
- Immune to sunlight
- Detecting range of 4000mm

**81-20**  
COMPLIANT

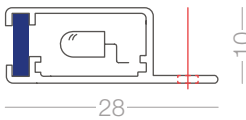

**VERSATILE**  
MODEL 03.G5.K194

- 194 beams from 40 diodes
- Standard height of 2000mm
- IP54 rating
- Immune to sunlight
- Detecting range of 4000mm

**81-20**  
COMPLIANT

**81-70**  
COMPLIANT

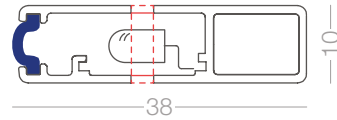

**OEM REPLACEMENT**  
MODEL 03.G5.B174

- 174 beams from 36 diodes
- Standard height of 2000mm
- IP54 rating
- Immune to sunlight
- Detection range of 4000mm

**81-20**  
COMPLIANT

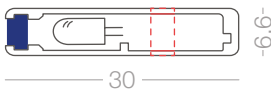

**SLIM PROFILE**  
MODELS 03.G5.SIX 126/169/174

- 126/169/174 beams from 24/35/36 diodes
- Heights: 1800/1950/2000mm
- IP54 rating
- Immune to sunlight
- Detecting range of 4000mm

**EXCLUSIVE!** ONLY AT **WECO**

**81-20**  
COMPLIANT

**81-70**  
COMPLIANT

**6.6mm**

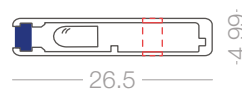

**SUPERSLIM**  
MODEL 03.G5.FOUR

- 234 crossed beams
- 96 diodes in TX / 48 in RX
- Standard height of 2000mm
- IP54 rating
- Immune to sunlight
- Detection range 500-1500mm

**EXCLUSIVE!** ONLY AT **WECO**

**81-20**  
COMPLIANT

**81-70**  
COMPLIANT

**4.99mm**

INCLUDES

Fixing kit	+	Cables	+	Power supply
------------	---	--------	---	--------------

Note: power supply is not included for direct connection door detector models.

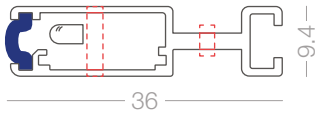

**UNIVERSAL**  
MODELS 03.G5.UPF 169/174

- 169/174 beams from 35/36 diodes
- Heights: 1800/1950mm
- IP54 rating
- Immune to sunlight
- Detecting range of 4000mm
- Direct connection

**81-20**  
COMPLIANT

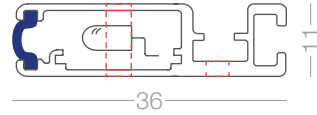

**MULTIPLE HEIGHTS**  
MODELS 03.G5.N 22/46/70/174

- 22/46/70/174 beams from 8/16/24/36 diodes
- Heights: 520/1000/1500/2000mm
- IP54 rating
- Immune to sunlight
- Detecting range of 4000mm

**81-20**  
COMPLIANT

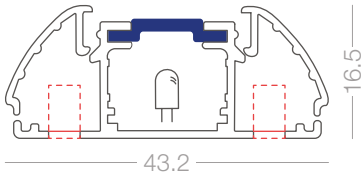

**SURFACE MOUNTING**  
MODELS 03.G5.J 174/234

- 174/234 beams from 36/48 diodes
- Standard height of 2000mm
- IP54 rating
- Immune to sunlight
- Detecting range of 4000mm

**81-20**  
COMPLIANT

**81-70**  
COMPLIANT

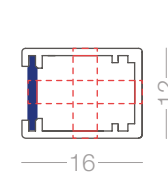

**FRONT AND SIDE FIXING**  
MODEL 03.G5.CDZ.174 101/XXX

- Direct connection or power supply
- 174 beams from 36 diodes
- Standard height of 2000mm
- IP54 rating
- Light immunity 100,000lux
- Detecting range of 4000mm

**81-20**  
COMPLIANT

**NEW!**

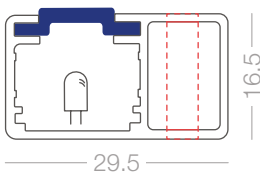

**LEADING EDGE**  
MODEL 03.G5.P174

- 174 beams from 36 diodes
- Standard height of 2000mm
- IP54 rating
- Immune to sunlight
- Detecting range of 4000mm
- Fixing brackets included

**81-20**  
COMPLIANT

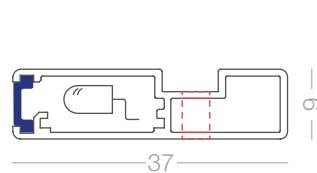

**VERSATILE**  
MODEL 08.G5.V174

- 174 beams from 36 diodes
- Standard height of 2000mm
- IP54 rating
- Immune to sunlight
- Detecting range of 4000mm

**81-20**  
COMPLIANT

INCLUDES

Fixing kit + Cables + Power supply

Note: power supply is not included for direct connection door detector models.

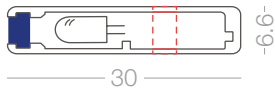

**EXTENDED DETECTION DISTANCE**  
MODEL 03.G5.SMX

- 194 beams from 40 diodes
- Standard height of 2000mm
- IP54 rating
- Immune to sunlight
- Detecting range of 6000mm

**81-20**  
COMPLIANT

**81-70**  
COMPLIANT

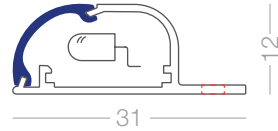

**3D DETECTION**  
MODEL 03.G5.3D3.206

- 194/16 beams from 40/16 diodes (2D/3D)
- Standard height of 2000mm
- IP54 rating
- Light immunity 100,000lux
- Detecting range of 3000 (2D)
- Detecting range of 1000mm (3D)



**81-20**  
COMPLIANT

**81-70**  
COMPLIANT

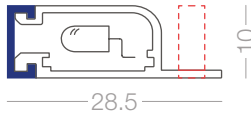

**WATERPROOF**  
MODEL 03.G5.M65.194

- 194 beams from 40 diodes
- Standard height of 2000mm
- IP65 rating
- Immune to sunlight
- Detecting range of 4000mm



**81-20**  
COMPLIANT

**81-70**  
COMPLIANT

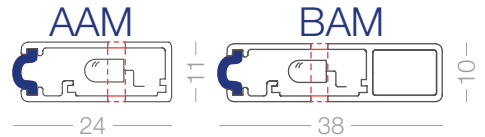

**AUTOSCAN FUNCTION**  
MODELS 03.G5.AAM94/BAM94

- 94 beams and 17 diodes
- Standard height of 2000mm
- Detecting range: 4000mm
- Immune to sunlight
- IP54 rating



**81-70**  
COMPLIANT

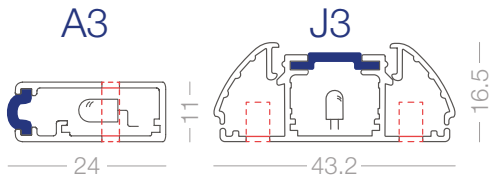

**TÜV CERTIFIED**  
MODELS A3/J3

- Conforms to 2006/42/EG Annex V (2), EN62061: 2005 + A1: 2013 + A2: 2015
- Standard height of 2000mm
- Detecting range: 500-2000mm
- IP54 rating
- TÜV certified control unit

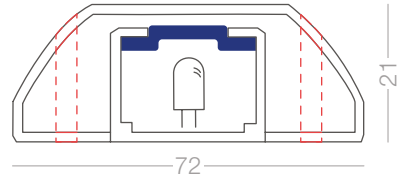

**TÜV CERTIFIED**  
MODEL 03.G5.SIL3

- Conforms to EN 81-20: 2014 5.11.1.1, EN 81-50: 2014 5.15, EN 81-1: 1998 + A3: 2009 14.1.1 "H" and EN 81-2: 1998 + A3: 2009 14.1.1 "H"
- Heights: 1800/2000/2500mm
- Detecting range: 1000-4000mm
- IP54 rating
- TÜV certified control unit

INCLUDES

Fixing kit + Cables + Power supply

Note: power supply is not included for direct connection door detector models.

## BRACKETS FOR STATIC INSTALLATION

### FR45

Heavy-duty bracket set.  
Brackets suitable for A, B, CMX,  
K, L, MD, M65, SIX and V profiles.

### KPC

Standard bracket set.  
Brackets suitable for L, N and UPF profiles.

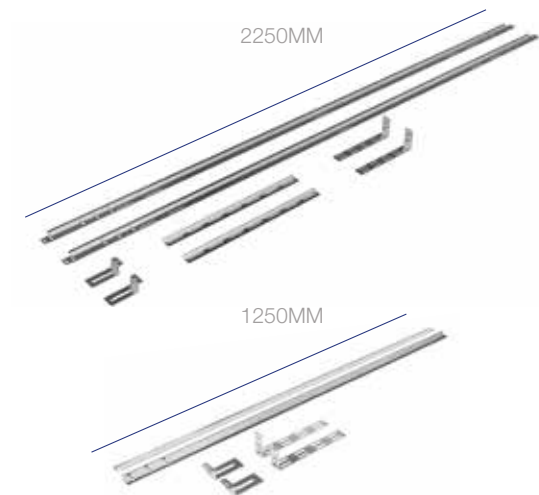

## CLIPS FOR DYNAMIC INSTALLATION

Between 3 and 6 clips are required per door panel and all fixing material is supplied in the package. Clips are available for the B and SIX.

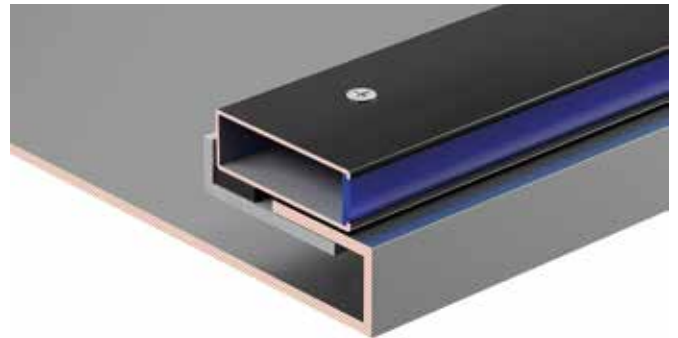

## CABLES FOR DOOR DETECTORS

### UF12



### UF11



### FOUR



### R24



## POWER SUPPLIES FOR DOOR DETECTORS

### FED



- 220VAC / 15-30VDC
- Internal LED indicators
- Status output
- EN 81-20
- Buzzer

### FD2



- 220VAC / 15-30VDC
- External LED indicators
- Status output
- EN 81-20

### BIV



- 220VAC-110VAC
- Bi-voltage
- Internal LED indicators
- Internal switch

### BVB



- 220VAC-110VAC
- Bi-voltage
- Internal LED indicators
- Internal switch
- Buzzer

### MTV



- 85-265VAC / 14-30VDC
- Multi-voltage
- Internal LED indicators
- Nudging
- Buzzer

### FX6



- 24VDC-220VAC
- Multi-voltage
- Internal LED indicators
- Status output
- Multiple outputs
- Relay output N/O or N/C
- Transistor output NPN or PNP
- Buzzer

### XN5



- 220VAC / 110VAC
- Internal LED indicators
- Nudging
- Buzzer

### KAP



- 220VAC / 110VAC
- External LED indicators

### DC3



- 15-30VDC
- External LED indicators

### UBX



- 85-265VAC – 100-300VDC
- Internal LED indicators
- Status output - diagnostic
- EN 81-20
- For UPF model

### MD3



- 220VAC
- Internal LED indicators
- Internal switch
- Buzzer
- For 3D3 model

### BEN



- 185-300VAC / 25VAC / 11-35VDC
- External LED indicators
- Feedback output
- EN 81-20

### LED PANEL CCT SERIES CABIN LIGHTING

- For all cabin types
- Quick and easy installation
- Uniform light spread
- Adjustable fixing brackets
- Hidden fixing points

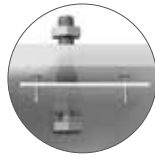

QUICK AND EASY  
INSTALLATION



ADJUSTABLE  
WHITE COLOUR



DEPTH OF  
JUST 10MM



EMERGENCY BATTERY  
(OPTIONAL)



**PLUG & PLAY**

### LED PANEL LP3 SERIES CABIN LIGHTING

- For all cabin types
- Quick and easy installation
- Uniform light spread
- Adjustable fixing brackets
- Hidden fixing points
- Available in warm, cold and natural white



QUICK AND EASY  
INSTALLATION



DEPTH OF  
JUST 8MM



EMERGENCY BATTERY  
(OPTIONAL)



**PLUG & PLAY**

### LED PANEL LP5 SERIES CABIN LIGHTING

- For all cabin types
- Frame depth 35mm
- Quick and easy installation
- Uniform light spread
- Fixing brackets included
- Hidden fixing points
- Integrated battery backup



HIDDEN FIXING  
BRACKETS



35MM  
ALUMINIUM FRAME



90 MINUTE BATTERY  
BACKUP



**PLUG & PLAY**

**COMPACT LED SPOT**  
**FCL & JBC SYSTEM**  
**CABIN LIGHTING**

- Available in white or chrome
- LED splitter with 6 outputs
- Battery backup up to 90/180mins (optional)



EASY CONNECTION



PRE-WIRED J CONNECTOR



EMERGENCY BATTERY (OPTIONAL)

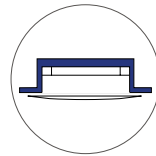

ANTI-TAMPER BRACKET



**PLUG & PLAY**

**LED SPOT**  
**ESL & DAISY CHAIN SYSTEM**  
**CABIN LIGHTING**

- Flush-mounted
- Spring-fixed
- Daisy chain system
- Available in silver



**COP LIGHTING**  
**EM44 SERIES**  
**CABIN LIGHTING**

- OEM COPs lighting replacement
- Quick and easy installation
- Energy efficient
- High LUX output
- 3 hour battery backup (optional)



## BATTERY FOR EMERGENCY LIGHTING EMA SERIES EMERGENCY SYSTEMS

- 60 minutes in emergency mode
- Input voltage 100-240VAC
- External alarm output
- Emergency light output
- Internal alarm 110dB
- Constant output 'P'



## VANDAL-RESISTANT ENSVR SERIES CABIN LIGHTING

- Impact resistant to IK08
- Flame resistant to 850°
- Vandal-resistant fixings



DEPTH OF  
JUST 22MM



VANDAL-RESISTANT  
TO 81-71

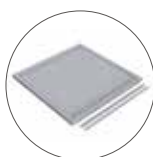

2 SIZES  
AVAILABLE



EMERGENCY  
BATTERY (OPTIONAL)



## VANDAL-RESISTANT PANEL WITH LED PANEL CABIN LIGHTING

- Easy installation
- Vandal-resistant fixings
- Depth of 34mm
- Impact resistant to IK08 (EN50295:98)
- 81-71 equivalent
- 2mm stainless steel



## LED FLEX BNX SERIES SHAFT LIGHTING

- Extremely flexible
- Energy efficient
- Rated to IP65
- TRI-CHIP technology: high output LED light
- Input voltage 230VAC
- Emergency battery (optional)



COMPACT COMPONENTS



EASY INSTALLATION



CAN BE CUT AT 1M INTERVALS

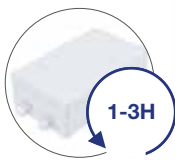

EMERGENCY BATTERY (OPTIONAL)



BN4 series - Economic range



BN6 series - Standard range



BND series - Premium range



BNN series - Halogen-free range

## LED FLEX KIT BND SERIES SHAFT LIGHTING

- Ready-to-use
- Drop switch (optional)
- Extremely flexible
- Rated to IP65
- Input voltage 230VAC
- Cold white (6500 K)
- Pre-cut lengths
- Emergency battery (optional)

Sizes available: 11m (2-3 floors), 17m (4-5 floors), 25m (6-7 floors), 33m (8-9 floors) and 50m (10-12 floors).



EASY INSTALLATION



ENERGY EFFICIENT LEDS



COMES WITH DROP SWITCH



EMERGENCY BATTERY (OPTIONAL)



## SLK LED SHAFT LIGHTING

### SLK SERIES

#### SHAFT LIGHTING

- Compact and robust
- Lightweight
- Up to 15 shaft lights can be linked together



EASY  
INSTALLATION



EASY  
CONNECTION



CABLES  
INCLUDED



## MAGNETIC EMERGENCY LIGHT

### 04.MEK.90M

#### MAINTENANCE / EMERGENCY SYSTEMS

- Perfect for maintenance work
- Optimal light
- Magnetic feet
- Lightweight



MAGNETIC  
FEET



90 MINUTE  
EMERGENCY TIME



INTEGRATED  
SWITCH

## MAGNETIC MAINTENANCE LIGHT

### 05.ML2.T6.300

#### MAINTENANCE

- Perfect for maintenance work
- Magnetic feet
- Lightweight
- 1.5m connection cable



## TOE GUARDS FOR HOME LIFTS AND PLATFORMS SECURITY SYSTEMS

- 2 or 3 stages
- Two adjustable rubber buffers to cushion the toe guard from the pit floor
- Suitable for speeds less than 0.65m/s
- Cables, shock absorbers and telescopic arms included
- Zinc-plated steel
- Made in Europe

Sizes available: 600, 700, 800 and 900mm. Other models with special dimensions available on request.



TELESCOPIC ARMS



SHOCK ABSORBERS



ZINC-PLATED STEEL

## MAINTENANCE SAFETY BARRIER 05.MSG.3PML SECURITY SYSTEMS

- Freely configurable three-section safety barrier
- Lightweight and robust
- Customisable
- Can be connected for longer lengths
- Easy handling



EASY HANDLING



ADJUSTABLE



INTEGRATED WHEELS



FOLDABLE

## SYSMIC SENSOR 07.SS.PQM SECURITY SYSTEMS

- Able to detect seismic movement in advance
- 2 alarms: primary waves and secondary waves
- 8 hours of autonomy
- IP65 rating



## LOAD WEIGHERS - LW8 SERIES

### CONTROLLER 03.LW8.CU22

The LW8 elevator load weigher system from WECO has a universal controller which connects to all load sensors and load cells in the LW8 series. This universal approach gives maximum flexibility on site, as well as reducing stock requirements. The system is suitable for both old and new elevators.

3x relay outputs | Analogue output | Overload audio warning



## ROPE SENSOR

### MODEL 04.LW8.R160

The R160 rope clamp is the preferred option when a rope sensor is required. It can be easily and quickly installed on the elevator suspension ropes from the cabin top. Suitable for new elevators and retrofits on old elevators.

Duty load 3000kg | Rope diameters 8-13mm | Automatic calibration



## BEAM SENSOR

### MODEL 04.LW8.B100

The B100 measures micro-deformations in the cross head of the elevator car frame. It is suitable all types of elevator, including large cabins and freight lifts. Due to its unlimited load capacity, it is especially suitable for heavy-duty elevators.

Unlimited duty load | Calibration with known weight



## UNDERFLOOR SENSOR

### MODEL 04.LW8.UCxx

The UCxx load cells are designed for installation between the car frame and the elevator cabin, where they give the most accurate load readings. It is the preferred option for new elevators, where the design allows. The UC-2 has two active and two passive load cells, while the UC-4 has four active load cells.

Duty load 3200kg | Automatic calibration



## SMART MIRROR ELEVATOR CABIN

Take your elevator experience to the next level! Enjoy apps and multimedia content with our new interactive WECO Mirror. Designed to impress, this innovative device combines style, functionality and entertainment. Featuring a high-tech design that fits into any environment, adding a touch of sophistication and modernity to the aesthetics of your elevator.

Wifi & Bluetooth | 32" touch screen | Android | Sensitivity settings



## DOOR DETECTOR - CIRCULAR DOORS MODEL 03.G5.YOP.194

WECO's latest infrared barrier is the ideal solution for lifts equipped with circular doors. Thanks to its optimal performance and high precision, it guarantees safe and efficient door opening and closing. What's more, its fixing fin design allows for quick and easy installation.

194 beams and 40 diodes | Standard height of 2040mm  
Detecting range: 0-1500mm | Immune to sunlight | IP54 rating



## ALARM BELL MODEL 03.ALR.624

Wall mounted piezoceramic alarm bell. Calibrated Hzt frequencies for ideal alarm sounds. Dimensions: 150x75x29mm.

Sound level 110dB | Power supply 6 ~ 24VDC | LED indicator - alarm on



## EUROPE

WECO EUROPEAN OPERATIONS  
LIMITED LTD.  
4/F Howleys Quay, Riverfront  
V94 WTK7 - Ireland

www.wecoeurope.com  
info@wecoeurope.com  
+353 87 053 2683

## GERMANY

WECO AUFZUGTEILE GMBH  
Lionstraße 12, 04177 Leipzig  
Germany

www.weco-aufzugteile.de  
info@weco-aufzugteile.de  
+49 (0) 341 49 310 100

## UK & IRELAND

WECO Elevator Products Ltd.,  
3rd Floor Northern Assurance  
Building, 9/21 Princess Street,  
Manchester M2 4DN, UK

www.wecouk.co.uk  
rlydon@wecoeurope.com  
+44 1618 840 635

## FRANCE BENELUX

WECO FRANCE S.A.R.L.  
LID de NICE lieu dit "la Bastié" 5ème  
avenue, BP 362, Carros Le Broc  
France

www.wecofrance.fr  
commercial@wecofrance.fr  
+33 4 9381 0353



## ITALY

WECO ITALY SRL  
Via Francesco Olgiati, 26  
20143 Milano – Italy

Magazzini & Logistica:  
Via Varese 3, 20098 San Giuliano  
Milanese (MI) – Italy

www.wecoitaly.com  
info@wecoitaly.com  
+39 0541 161 1848  
+39 327 546 3124

## SPAIN & PORTUGAL

WECO Lift Services, S.L.  
C/ Borges Blanques 22,  
Pol. Ind. La Borda, 08140,  
Caldes de Montbui,  
Barcelona - España

www.wecoelevator.com  
info@wecoelevator.com  
+34 93 865 47 18

## TURKEY

WECO TURKEY SAN.VE TIC. LTD.STI  
Serifali Mah. Kutup. Sok. No: 21  
Istanbul 34775 - Turkey

www.wecoturkey.com  
info@wecoturkey.com  
+90 535 821 69 21

## LATIN AMERICA

WECO GLOBAL OPERATIONS  
LIMITED LTD.  
Central logistics - Panamá Pacífico

www.wecolatam.com  
info@wecolatam.com  
+34 93 865 4718  
+34 679 811 785

## BRAZIL

WECO BRASIL MONTAGENS E  
INSTALAÇÕES ELÉTRICAS  
R. Caí, 270, Vila Princesa Izabel,  
Cachoeirinha, Rio Grande do Sul  
Brasil

www.wecobrasil.com  
info@wecobrasil.com  
+55 5122001111

## ASIA PACIFIC

WECO GLOBAL OPERATIONS  
LIMITED LTD.  
Suite 1213, Tai Yau Building, 181  
Johnston Road, Wanchai - Hong Kong

www.wecoglobal.com  
china@wecoglobal.com  
+86 13720345281

## WECO INDIA

WECO ELEVATOR PRIVATE  
LIMITED LTD.  
9/174,175, Samayapuram Nagar,  
Porur, Chennai, Tamil Nadu 600116  
Kerala - India

www.weco-india.com  
support@weco-india.com  
+91 908 756 3555

## WECO NEWSLETTER





